

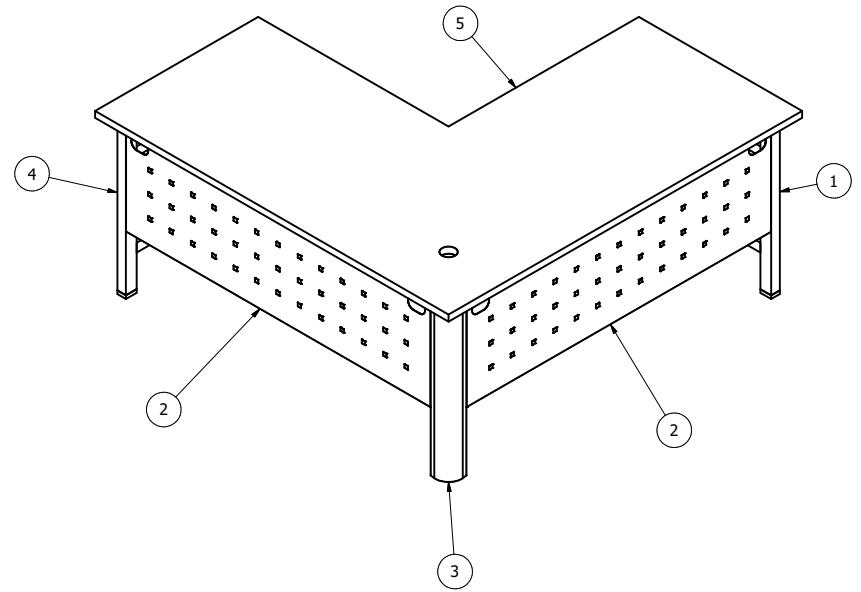

NOTES:

1. WORKSTATION CONFIGURATION IS USING A 56" METAL MODESTY PANEL.

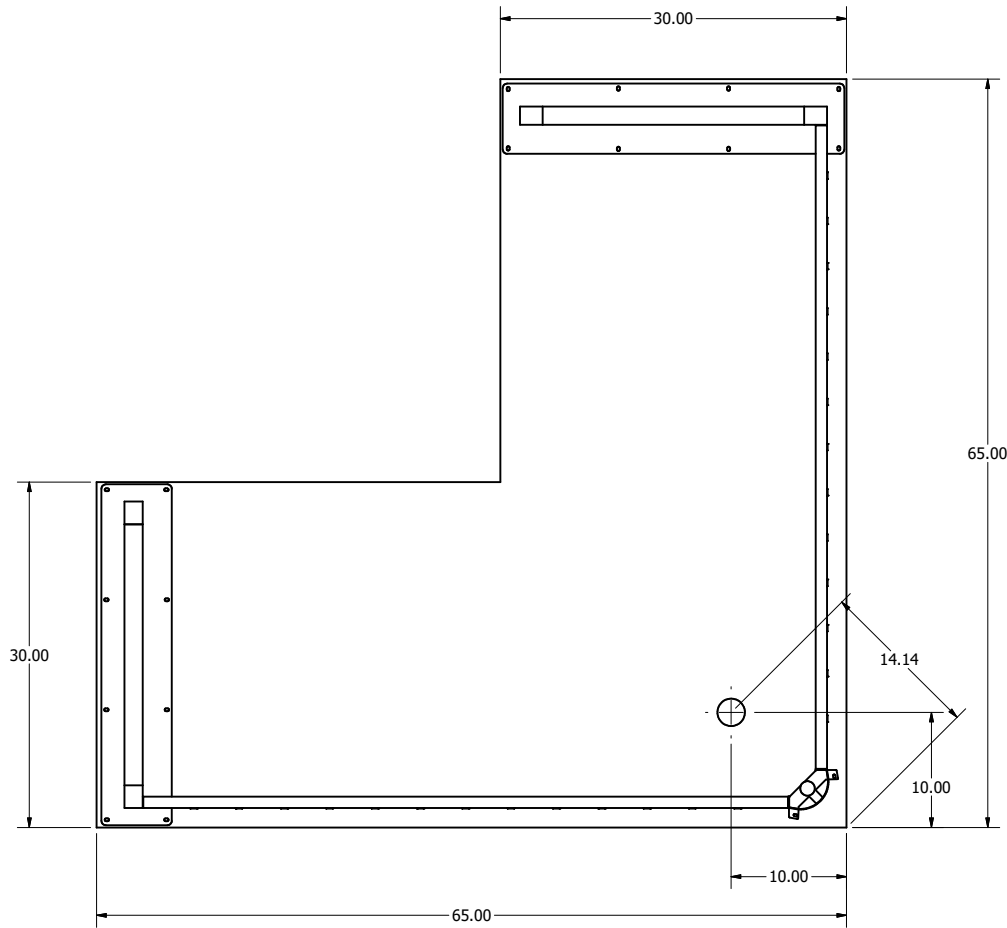

PARTS LIST			
ITEM	QTY	PART NUMBER	DESCRIPTION
1	1	HLEG30S-ML-L	30" "H" Legs - Left
2	2	RFP-CD-56	56" Metal Modesty Panel
3	1	RCL-01	Corner Leg
4	1	HLEG30S-ML-R	30" "H" Legs - Right
5	1	6530WS-90	65" x 65" x 30" 90 DEG Work Surface

Unless otherwise noted, deburr and break all sharp edges.	DRAWN BY:	Stephen Guess	12/8/2025	 Open Plan Systems 4700 Deepwater Terminal Rd. Richmond, VA, 23234 p. 844.OPS.OPS1 f. 804.275.2329	<small>PROPRIETARY AND CONFIDENTIAL</small> <small>The information contained in this drawing is the sole property of Open Plan Systems, Inc. Its reproduction or distribution in part or in whole without the written permission of Open Plan Systems, Inc. is prohibited.</small>				
	CHECKED BY:								
Tolerances:	QA APPROVED BY:			DESCRIPTION:	65" x 65" x 30" HLEG w/ Grommet				
	.X ± .063	MFG APPROVED BY:							
.XX ± .031	ENG APPROVED BY:			SIZE	C	DWG NO	30 LEG W 56 MOD PANEL 90DEG	REV	
.XXX ± .016	MATERIAL:			SCALE	0.08	SHEET	1 OF 1		
ANGLES ± 1'	FINISH:			DRAWING STATUS:					
	SERIES:								