

CLASSIC VT

POWERED ADJUSTABLE HEIGHT TABLE

SPECIFICATIONS



CONFIGURATION

Specifications

Keypad	LED Display two-button up-and-down keypad
Motor	2-Stage Lift/Dual Motor
Foot Style & Length	T-Leg – 23.6"
Height Range (excl. top)	26.4" to 45.8"
Work Surface Widths	46" to 72"
Work Surface Depths	24", 30" and 36"
Max Lifting Capacity	250 lbs.
Speed	1.26 in/sec (32 mm/sec)
Anti-Collision	Yes
Wire Management	Wire Tray included/Additional sold separately
Weight	57 lbs.

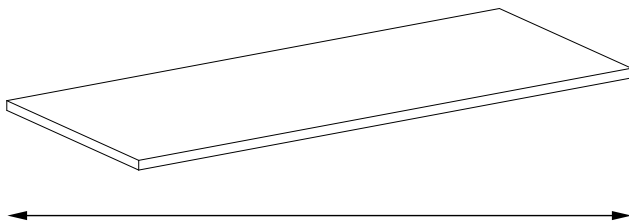

Top Widths: 46" - 72"

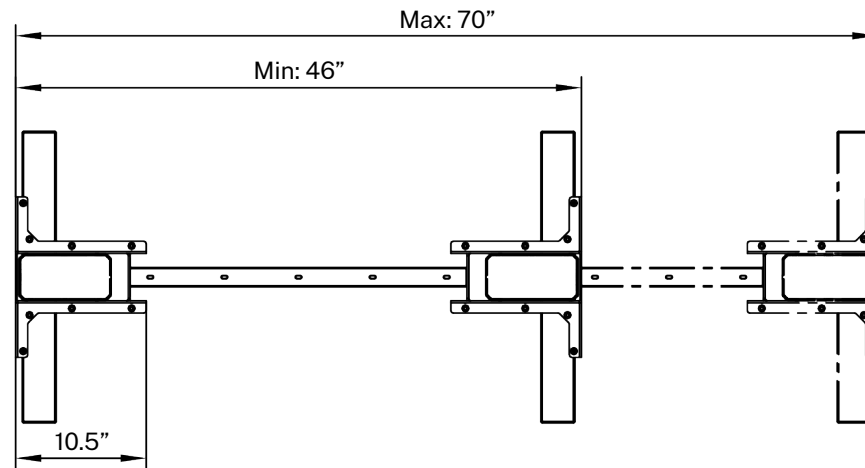
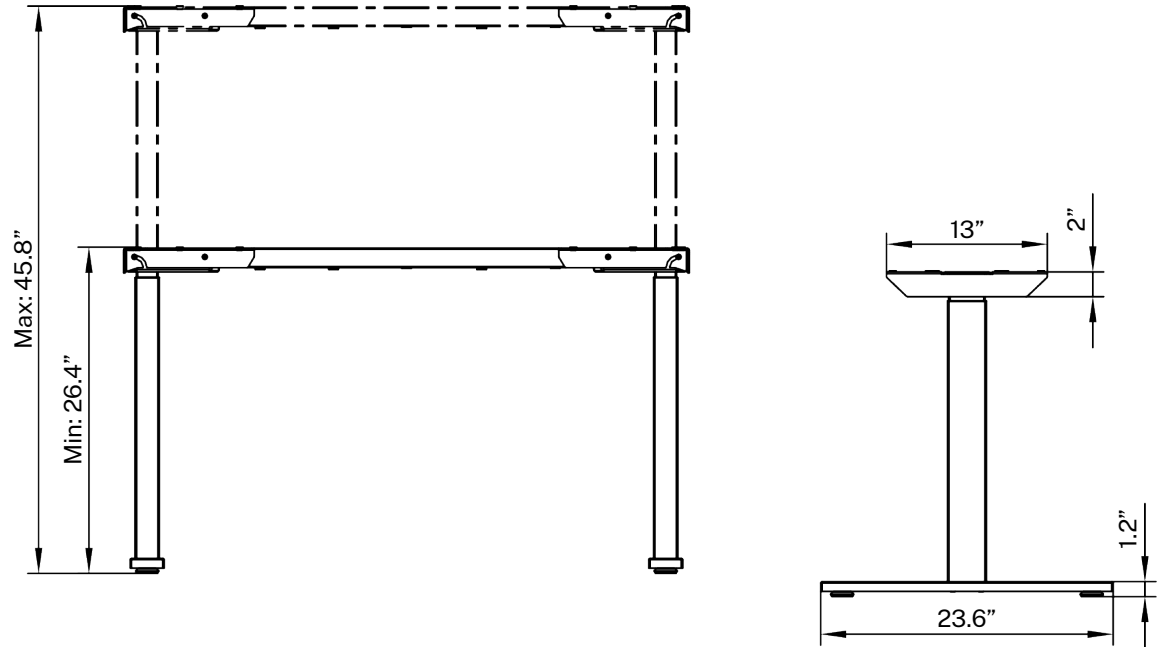

CONFIGURATION

JC Gyro Control Box

Input voltage: 100-120VAC

Frequency or AC/DC: AC&DC

Current/watts: 350W 3-Prong

Maximum ampere rating, motor: 5A±10%

Gyro sensor built in; the port for column comes from either side

